

744i Series:

The KDF *744i Series* is a large area, four-target, batch sputtering system, designed for processing high-density interconnect, 200 mm semiconductor wafers, OLED and flat panel displays. The tool was developed to meet increasing customer demand for higher throughput with larger substrates.

- **Vertical side sputtering system**
- **19" x 19" pallet size**
- **Compact footprint that uses less than one third of the space required for competing equipment**
- **High-vacuum loadlock with quartz heater lamps for efficient degassing of substrates**
- **Capacity to process up to four 200 mm wafers or multiple smaller wafers at once**
- **Throughput for 200 mm wafer metallurgy is increased four times over that of a *600i Series* system**
- **Glass sizes up to Gen 2**
- **Pallet assist tool (PAT) for handling up to 60 lb pallet payloads in a safe and repeatable manner**
- **Optional OPUS Robot designed for particulate-free, reliable cassette to cassette substrate handling operations**
- **Optional integrated RGA for process and fault monitoring of gas peaks along with integrated hi vac step**
- **Optional Rotating Substrate pallet for optical market demands**

The tool features a four target main chamber system. Pallets allow instantaneous change of wafer sizes and the ability to process either the front or backside of the wafer.

The *744i Series* is also available with an optional 20 kw DC Pinnacle plus pulse sput and pulse bias configuration.



In line with your process

The most reliable in-line sputtering tools in the industry are developed and manufactured by KDF. All of KDF's systems are engineered to meet versatility and high throughput demands across a number of markets at the industry's lowest cost of ownership.

- **Mainstream silicon**
- **Emerging materials**
- **Flat panel displays**
- **Optical communications**
- **Medical devices**

Across all platforms, KDF's in-line batch sputtering systems are easier to use and maintain than cluster tools. KDF's solutions provide users with increased:

- **Film uniformity**
- **Throughput run to run**
- **Process stability**
- **ROI**
- **Automation**
- **Tool uptime**
- **Reliability**
- **Environmental health and safety benefits**

KDF meets the needs of its customers by quickly developing tailored solutions and building on its core competencies. KDF can specifically engineer its tools for increased throughput, ROI or time to market. All existing KDF equipment is supported with upgrades and retrofits. In addition, as the OEM for MRC batch systems, KDF sustains all MRC batch products offering complete parts and service support on a world wide basis.

744i SERIES



The KDF 744i tools can be fitted with a variety of cathodes. There are Inset Cathodes™, which measure 24.5 inches in length, accommodating most metal and all precious metal types while providing higher cathode-to-pallet aspect ratio and improved uniformity. The Magterial Cathode™, a planar-type cathode, is ideal for magnetron sputtering or ferrous metals such as nickel and iron at high rates and high uniformities.

The KDF 744i tools can also be fitted with variety of other cathode styles, including the Mark II™. For sputtering dielectric materials such as SiO₂, or for reactive depositions of material such as indium-tin oxide, the Mark II™ is an ideal cathode for improved magnet design, better uniformity and longer life. The new RF capable KDF LMM™ full face erosion cathode is also available. KDF's in-house engineering staff models and designs all of our own customer and field proven cathodes. Optional gas delivery systems allow for enhanced reactive processes.

744i Vacuum Specifications

- Chamber ultimate $\leq 1 \times 10^{-7}$ torr.
- Chamber leak rate, 20 minutes to 1×10^{-4} torr.
- High vacuum dome ultimate $\leq 1 \times 10^{-7}$ torr.
- High vacuum dome leak rate, 15 minutes to 1×10^{-4} torr.
- Pump down from atmosphere 110 minutes or less to 1×10^{-6} torr or 2×10^{-7} torr overnight.

744i System Hardware Features

- 20kW low stored energy DC power supplies (Advanced Energy). Optional Pinnacle Plus power supplies.
- Integrated throttling SS VAT valve allowing for upstream or down stream pressure control.
- MKS multi component "Smart" 390 and 925 gauges for integrated vacuum measurements.
- Loadlock linear sensor – computer controller positioning system for increased loadlock accuracy and more limited fail-safe.
- Process gas control with up to four gas controllers; feedback controlled capacitance manometer; master/slave gas select ability; and gas ratio control.
- Stepper motor pallet carrier drive with optical encoder providing accurate programmable pallet carrier positioning, scan velocity profiling available.
- Low pressure hydraulics system for safety and smooth operation.
- Automated motor driven load lock door.
- Complies with NFPA79 guidelines.
- Optional 3kW RF solid state power supply (Advanced Energy).
- Consult factory for an extensive list of standard options.

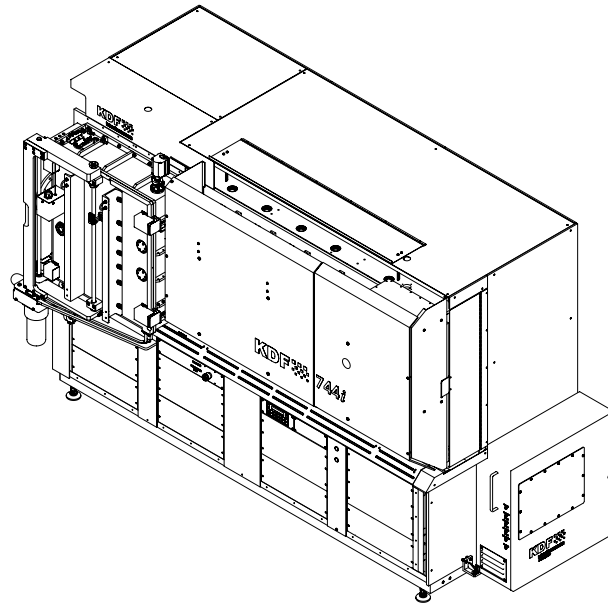

744i Computer Sub-System

- Windows™ 10 based real-time GUI environment, coupled with 24" LCD touchscreen monitor mounted on an umbilicated mobile HI cart.
- Context sensitive recipe manger running out of Microsoft® SQL database.
- Fully integrated package for real-time data display, data logging fully compatible with Excel™, Lotus™ and other Windows™ applications, report generation, remote interface and printing.
- Optional connectivity to SECS/GEM communication and Windows™ applications through and OPC server interface.
- Distributed Rockwell Control System utilizing Device Net and Ethernet IP field bus technologies.
- Maintenance test suite with full diagnostic and manual process control capability.
- Service friendly fully enclosed electronic cabinet

744i Basic Facility Requirements

- Power: 208 VAC, 3-phase, 225 Amps.
- Water: 8 GPM, 70 PSIG min., 10°C - 24°C.
- Compressed Air: 85 - 100 PSIG.
- Process Gas: 25 PSIG 99.999%.
- Pure Gas: Dry N₂.

SYSTEM CAPACITY							
744i PALLET 19" x 19"	2" wafers	3" wafers	4" wafers	5" wafers	6" wafers	8" wafers	300mm
	81	36	16	9	9	4	1

* Contact KDF for details on the many optional features available for 744i systems. Specifications subject to change.



10 Volvo Drive
Tel 201-784-5005

Rockleigh, NJ 07647
Fax 201-784-0202

www.kdf.com

744i SERIES